

4 YARN SIZING/FINISHING MACHINE

TYPE FIOMAT-B

GENERAL DESCRIPTION

Pilot machine for continuous yarn sizing / finishing, with cold or hot impregnation (95°C), for up to 4 yarns.

Holder for 4 yarn bobbins, impregnation trough with electric heating, squeezing padder, hot air insufflation tunnel and reel to upwind yarns.

Transport speed adjustable from 1 to 20 m/min.

Impregnation padder with pneumatic load system, roller width 115mm and roller diameter 110mm. One stainless steel roller, and one nitrilic rubber covered roller (hardness 65-70 Shore A).

1 liter trough with removable immersion rollers (for cleaning).

Hot air channel with fan and electric heaters, up to 150°C.



impregnation padder
with heated trough

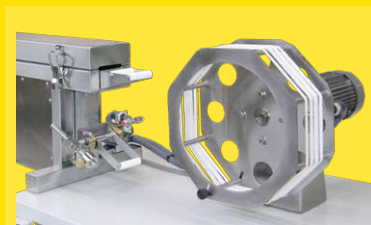

yarn tension control (compensator
arm) and reel for up to 4 yarns

TECHNICAL DATA - TYPE FIOMAT-B

Number of yarns	up to 4
Transport speed	1 - 20 m/min
Trough volume	1 liter
Temperature on trough	up to 95 °C
Padder roller width	115 mm
Padder roller diameter	110 mm
Padder roller material	1 stainless steel / 1 nitrilic rubber covered
Temperature of dryer channel	up to 150 °C

Electric power	3 x 220 V (50 / 60 Hz)
Weight (approx.)	250 kg

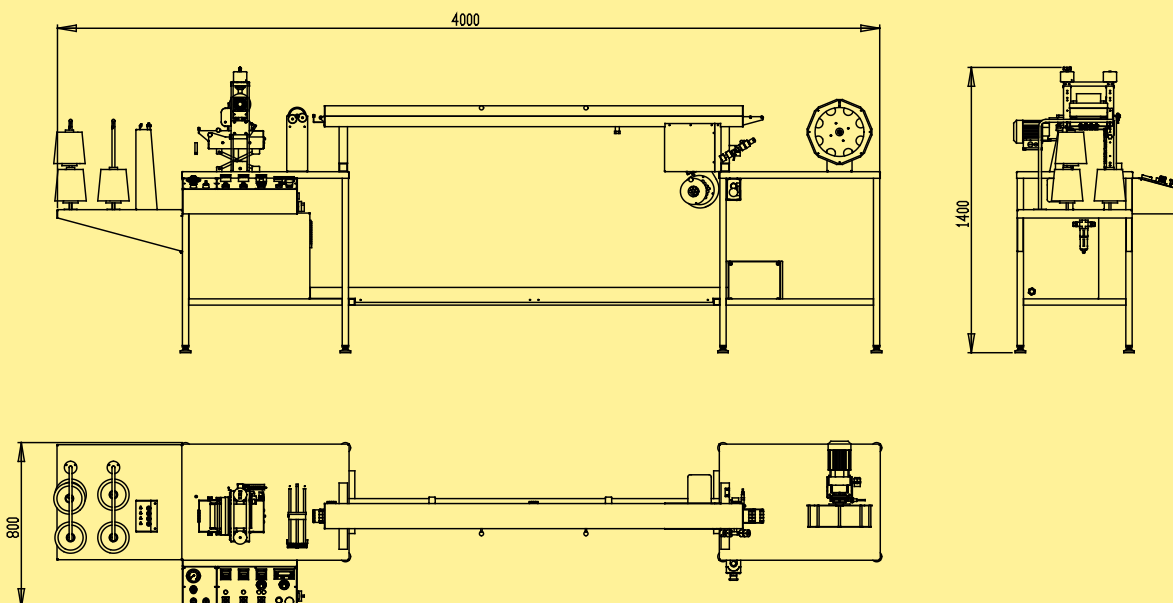

Werner Mathis AG
 Rütisbergstrasse 3
 CH-8156 Oberhasli/Zürich, Switzerland
 Telefon 41(0)44-852 5050
 Telefax 41(0)44-850 6707
 E-Mail info@mathisag.com
 Homepage www.mathisag.com

Aparelhos de Laboratório Mathis Ltda.
 Estrada dos Estudantes, 261
 06707-050 Cotia - SP, Brasil
 Tel: 55 (0)11 3883-6777
 Fax: 55 (0)11 3883-6750
 E-mail: mathis@mathis.com.br
 Site: www.mathis.com.br