

# PASTE EVACUATING DEVICE VACUUMAT TYPE «LPE»

Remove air bubble from pastes

This table model can be used where air and bubble free pastes, lacquers etc. are required.



[www.mathisag.com](http://www.mathisag.com)

### Working method

The material to be deaerated is poured in a disposable beaker and the latter is placed in a glass container. By lifting up the bottom part the stirrer is dipped into the beaker.

The remaining air is evacuated by a vacuum pump which is controlled by a timer.

The number of stirrer rotations is infinitely variable which avoids an overflow of the paste under vacuum. The unit is also equipped with an airing valve as well as a manometer for the indication of the vacuum. The evacuating process can be watched through the glass container.

### Technical information

Mixing content:	up to approx 1 litre
Rotations stirrer:	50 - 1500 rpm
Evacuating time:	approx 30 min
Weight:	~44 kg

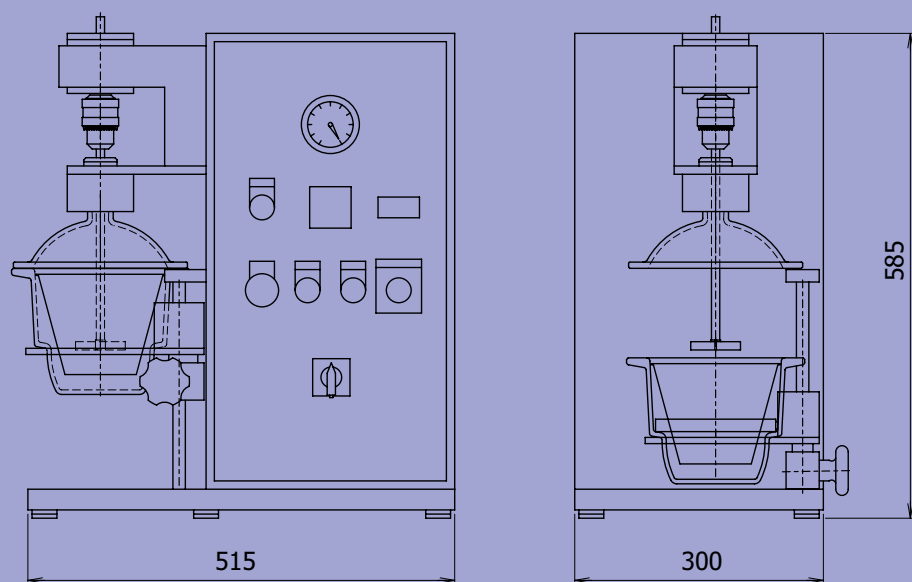

#### Werner Mathis AG

Rütisbergstrasse 3  
CH-8156 Oberhasli/Zürich, Switzerland  
Telefon: +41 44 852 50 50  
Telefax: +41 44 850 67 07  
info@mathisag.com  
www.mathisag.com

#### Werner Mathis U.S.A. Inc.

2260 HWY 49 N.E./P.O. Box 1626  
Concord N.C. 28026, U.S.A.  
Phone: +1 704 786 6157  
Fax: +1 704 786 6159  
usa@mathisag.com

#### Mathis (India) PVT. LTD.

No.01, Shreeji Arcade  
1st Floor, Opp. Nitin Co.  
Almeida Road, Thane 400 602  
Phone/Fax: +91 22 2538 5472  
india@mathisag.com

#### Aparelhos de laboratorio Mathis Ltda

Estrada dos Estudantes 261  
CEP 06707-050 COTIA S.P., Brasil  
Phone: +55 11 3883 6777  
Fax: +55 11 3883 6750  
brasil@mathisag.com